

SPARE PARTS LIST

Electric Pallet Truck SPTE15X/PTE15X

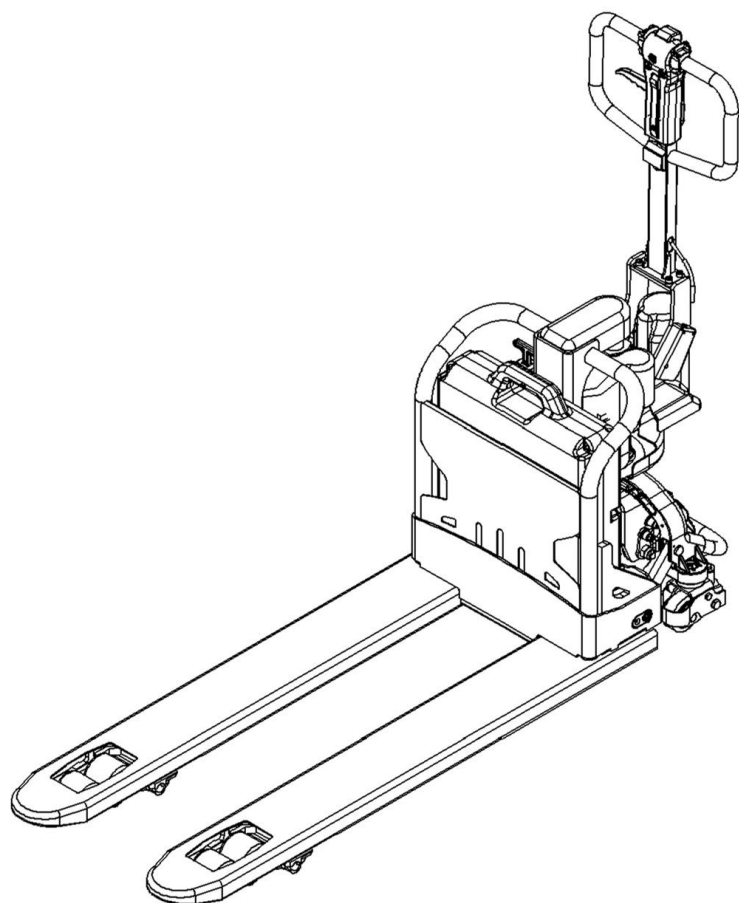

Version 05/2017

From truck identification number:

20170500001

SPTE15X/PTE15X -BPT-001-EN

Catalogue

Fig. 1 Spare parts for frame(540x1150).....	3
Fig. 2 Spare parts for frame(685X1220).....	5
Fig. 3 Load roller.....	7
Fig. 4 Drive system.....	9
Fig. 5 Drive wheel.....	11
Fig.6 EPB.....	12
Fig.7 Hydraulic parts (SPTE15X).....	13
Fig.8 Hydraulic parts (PTE15X).....	15
Fig.9 Castors.....	18
Fig.10 Handle bar (SPTE15X).....	20
Fig.11 Handle bar (PTE15X).....	22
Fig. 12 Truck parts.....	24
Fig.13 Power supply assembly.....	26
Fig.14 Electronic control assembly.....	27
Fig. 15 Charger assembly (standard).....	28
Fig.16 Main cables (SPTE15X).....	29
Fig.17 Main cables (PTE15X).....	30
Fig.18 Sticker for EU.....	31
Fig. 19 Sticker for US.....	32
Easy worn parts list.....	33

Fig. 1 Spare parts for frame (540x1150)

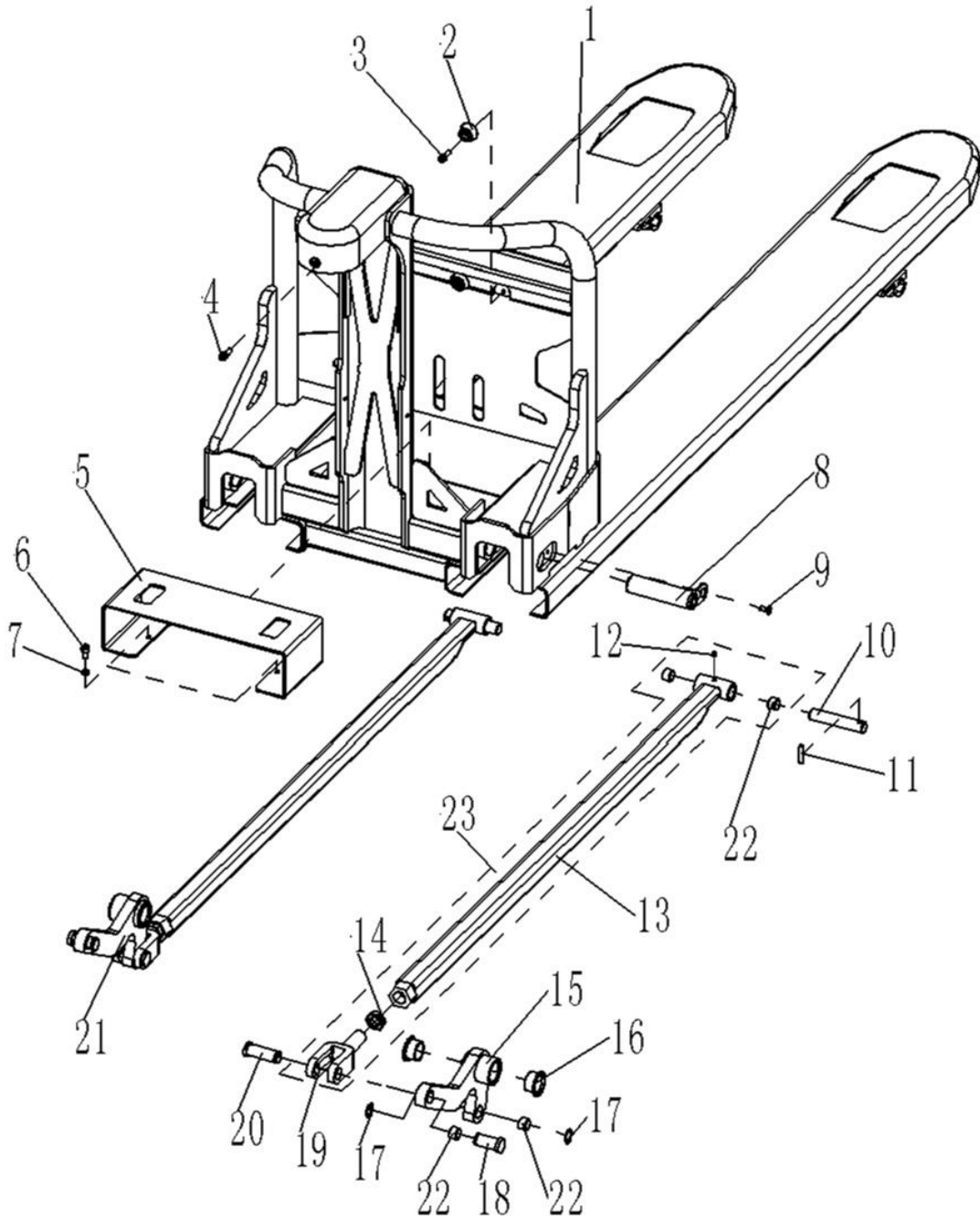

Fig. 1 Spare Parts for Frame(540X1150)

No.	Art No.	Description	Qty.	Note
1	502138510000	Chassis	1	
2	502038520029	Limit pad	4	
3	910200600023	Screw	4	M6x12
4	910200200035	Screw	1	M6x16
5	502138520024	Support plate	1	
6	910200200021	Screw	2	M5x10
7	910400500004	Washer	2	5
8	502038510006	Axle	2	Φ 20x100
9	910200400017	Screw	2	M6x16
10	502338520030	Axle	2	Φ 16x82
11	910600400025	Dowel pin	2	5x30
12	911200100001	Grease nipple	2	6
13	502138510001	Push rod	2	
14	910300400008	Nut	2	M20x1.5
15	502038510004	Rock arm (right)	1	
16	940500200009	Bushing	4	Φ 20xΦ 23x21.5
17	910401300007	Circlip	4	16
18	502338520037	Axle	2	Φ 16x35
19	502338520027	Push rod fork	2	
20	502338520026	Axle	2	Φ 16x46
21	502038510005	Rock arm (left)	1	
22	940500100006	Bushing	8	Φ 16xΦ 18x15
23	502198510000	Push rod kit	2	1150

Fig. 2 Spare parts for frame(685X1220)

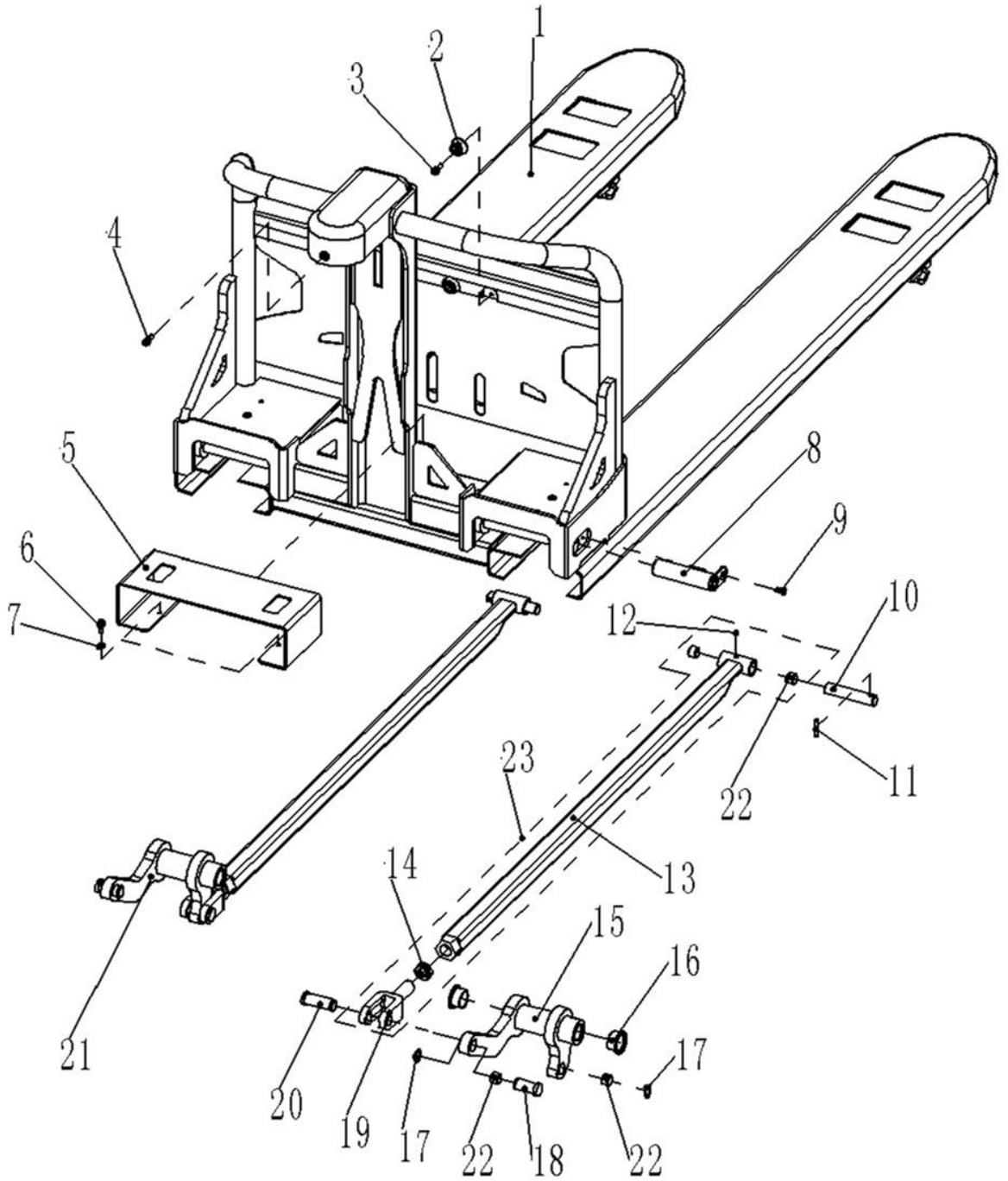

Fig. 2 Spare Parts for Frame(685X1220)

No.	Art No.	Description	Qty.	Note
1	502138510002	Chassis	1	
2	502038520029	Limit pad	4	
3	910200600023	Screw	4	M6x12
4	910200200035	Screw	1	M6x16
5	502138520024	Support plate	1	
6	910200200021	Screw	2	M5x10
7	910400500004	Washer	2	5
8	502038510010	Axle	2	Φ 20x177
9	910200400017	Screw	2	M6x16
10	502338520030	Axle	2	Φ 16x82
11	910600400025	Dowel pin	2	5x30
12	911200100001	Grease nipple	2	6
13	502138510003	Push rod	2	
14	910300400008	Nut	2	M20x1.5
15	502038510008	Rock arm (right)	1	
16	940500200009	Bushing	4	Φ 20x Φ 23x21.5
17	910401300007	Circlip	4	16
18	502338520037	Axle	2	Φ 16x35
19	502338520027	Push rod fork	2	
20	502338520026	Axle	2	Φ 16x46
21	502038510009	Rock arm (left)	1	
22	940500100006	Bushing	8	Φ 16x Φ 18x15
23	502198510001	Push rod kit	2	1220

Fig. 3 Load roller

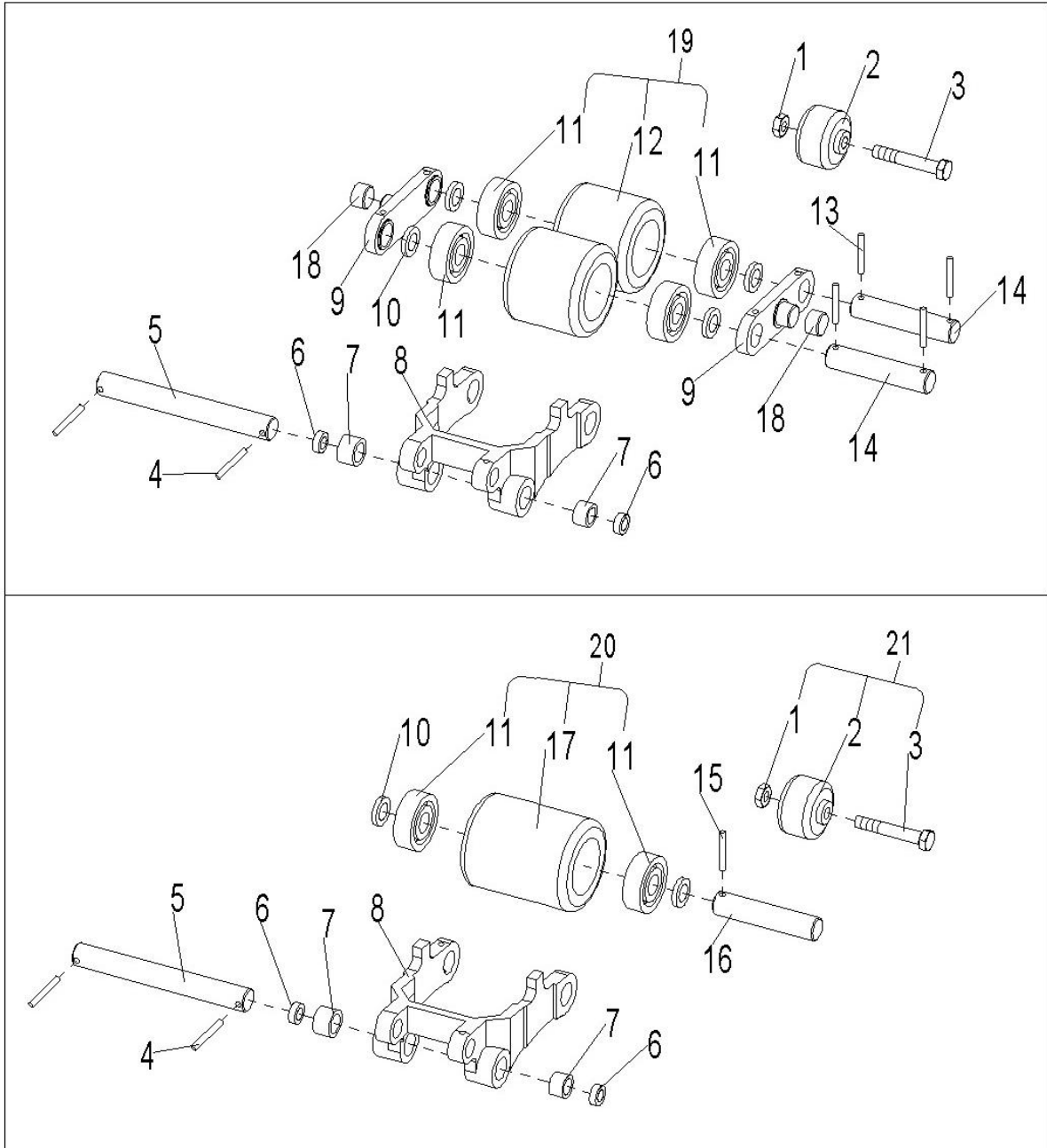

Fig. 3 Load Roller

No.	Art No.	Description	Qty.	Note
1	910300500005	Lock nut	2	M10
2	505638520039	Entry roller	2	
3	910100100035	Bolt	2	M10×60
4	910600400025	Dowel pin	4	Φ 5×30
5	300572020001	Lever block axle	2	
6	502338520033	Exit roller	2	
7	940500100012	Bushing	4	Φ 20xΦ 22x12
8	302538520065	Lever block	2	85mm
		Lever block	2	75mm
9	502317020000	Linking plate	4	tandem
10	940600500013	Washer	8/4(D/S)	
11	910700200019	Bearing	8/4(D/S)	6204
12	940300300005	Castor	4(D)	Φ 80x70
13	910600400027	Dowel pin	8(D)	5x35
14	502317020001	Castor axle	4(D)	Φ 20x94
15	910600400027	Dowel pin	8(D)	5x35
16	301017020001	Castor axle	2(S)	Φ 20x122
17	940300300023	Castor	2(S)	Φ 80x93
18	940500200003	Bushing	4 (D)	Φ 18xΦ 20x12
19	502198510002	Wheel set kit	4	
20	502198510003	Wheel set kit	2	
21	502198510004	Entry roller kit	2	

Fig. 4 Drive system

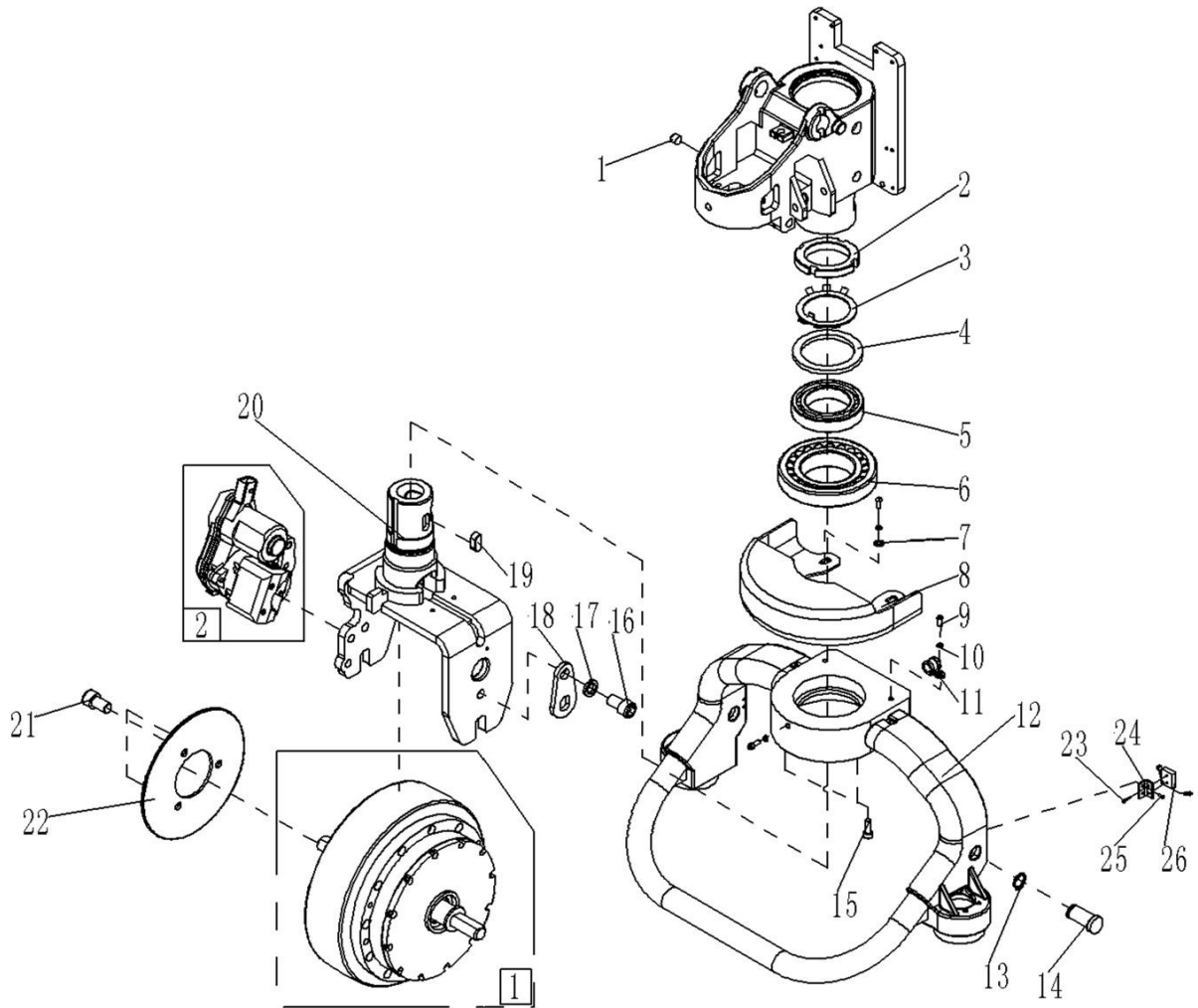

Fig. 4 Drive system

No.	Art No.	Description	Qty.	Note
1	910200800025	Screw	1	M10x12
2	910300700004	Nut	1	M52x1.5
3	910400900012	Washer	1	52
4	503213520001	Dust ring	1	
5	910700600034	Bearing	1	32911
6	910700600006	Bearing	1	30212
7	910400100005	Washer	4	6
8	502013520006	Plastic cover	1	
9	910200200035	Screw	4	M6x16
10	910400500005	Washer	4	6
11	951000100003	YGE hose clamp	1	
12	502013510000	Drive wheel frame	1	
13	910401300007	Circlip	2	16
14	502338520037	Axle	2	Φ 16x35
15	910200200053	Screw	2	M8x12
16	910200200096	Screw	2	M12x20
17	910400500008	Washer	2	12
18	502113520004	Fixing plate	2	
19	910600800025	Key A	1	10x22
20	502113510000	Flange frame	1	
21	502113520007	Screw	3	M8X20
22	940700300001	Braking plate	1	158x58x3.5
23	910200500003	Screw	2	M2x10 for PTE15X
24	502313520004	Micro switch assembly plate	1	for PTE15X
25	910200200013	Screw	3	M4x10 for PTE15X
26	920200300006	Micro switch	1	for PTE15X
①	502198510005	Drive wheel kit	1	
②	502112001000	Braking kit	1	

Fig. 5 Drive wheel

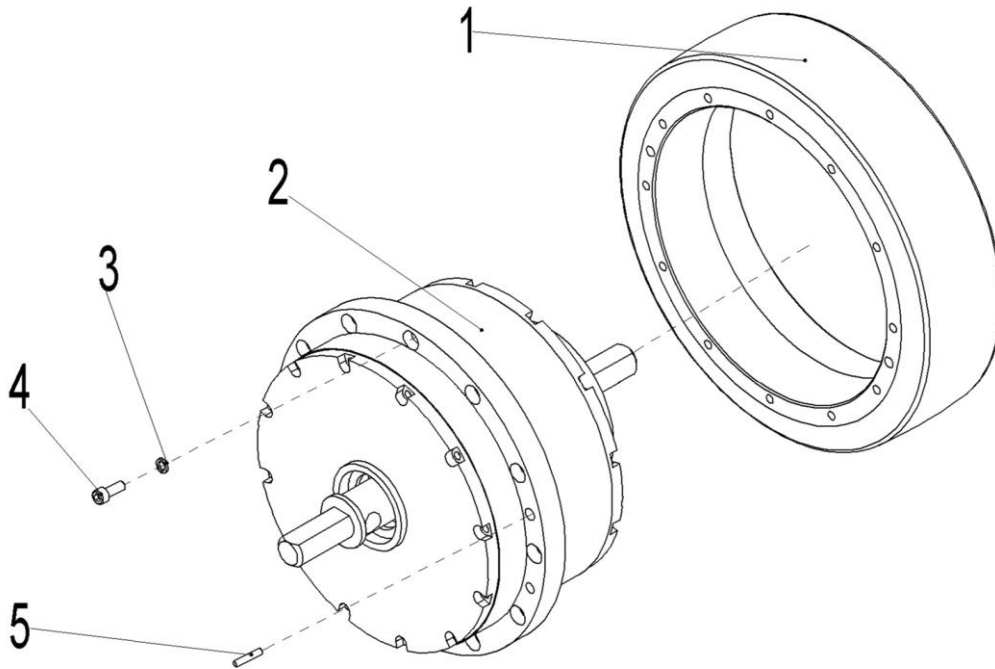

Fig. 5 Drive wheel

No.	Art No.	Description	Qty.	Note
1	940300300004	Wheel	1	
2	920900100057	Motor	1	
3	910400500005	Washer	12	6
4	910200200036	Screw	12	M6x20
5	910600100014	Pin	2	6x26

Fig.6 EPB

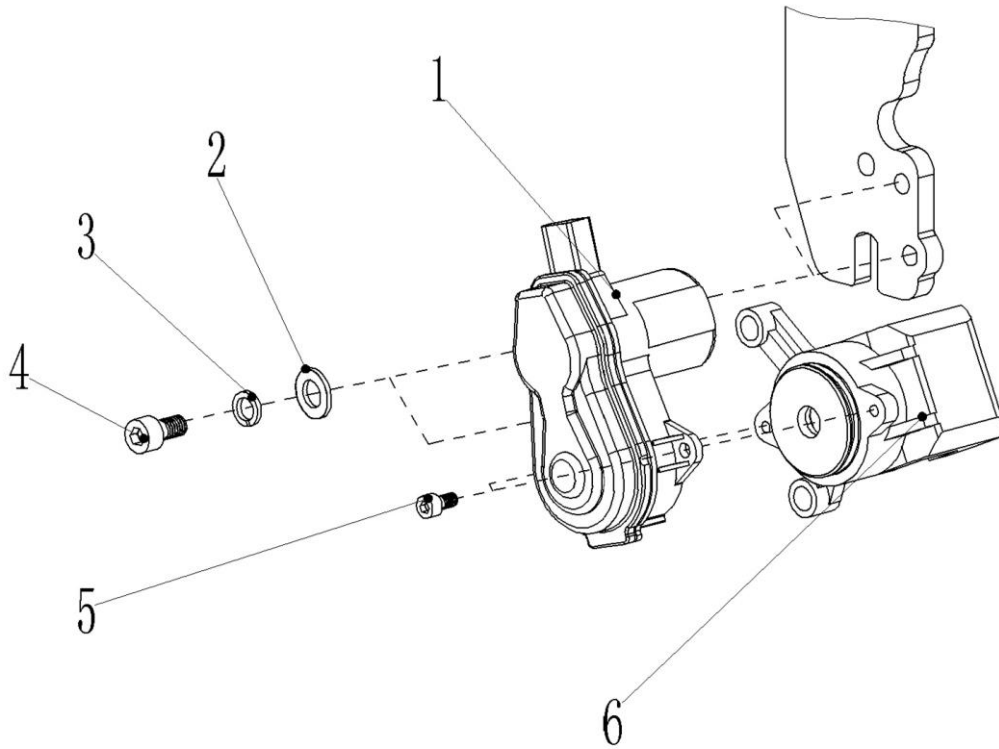

Fig.6 EPB

No.	Art No.	Description	Qty.	Note
1	502112010001	EPB	1	
2	910400100006	Washer	2	8
3	910400500006	Washer	2	8
4	910200200057	Screw	2	M8x20
5	910200200033	Screw	2	M6x12
6	502112010002	Braking block	1	

Fig.7 Hydraulic parts (SPTE15X)

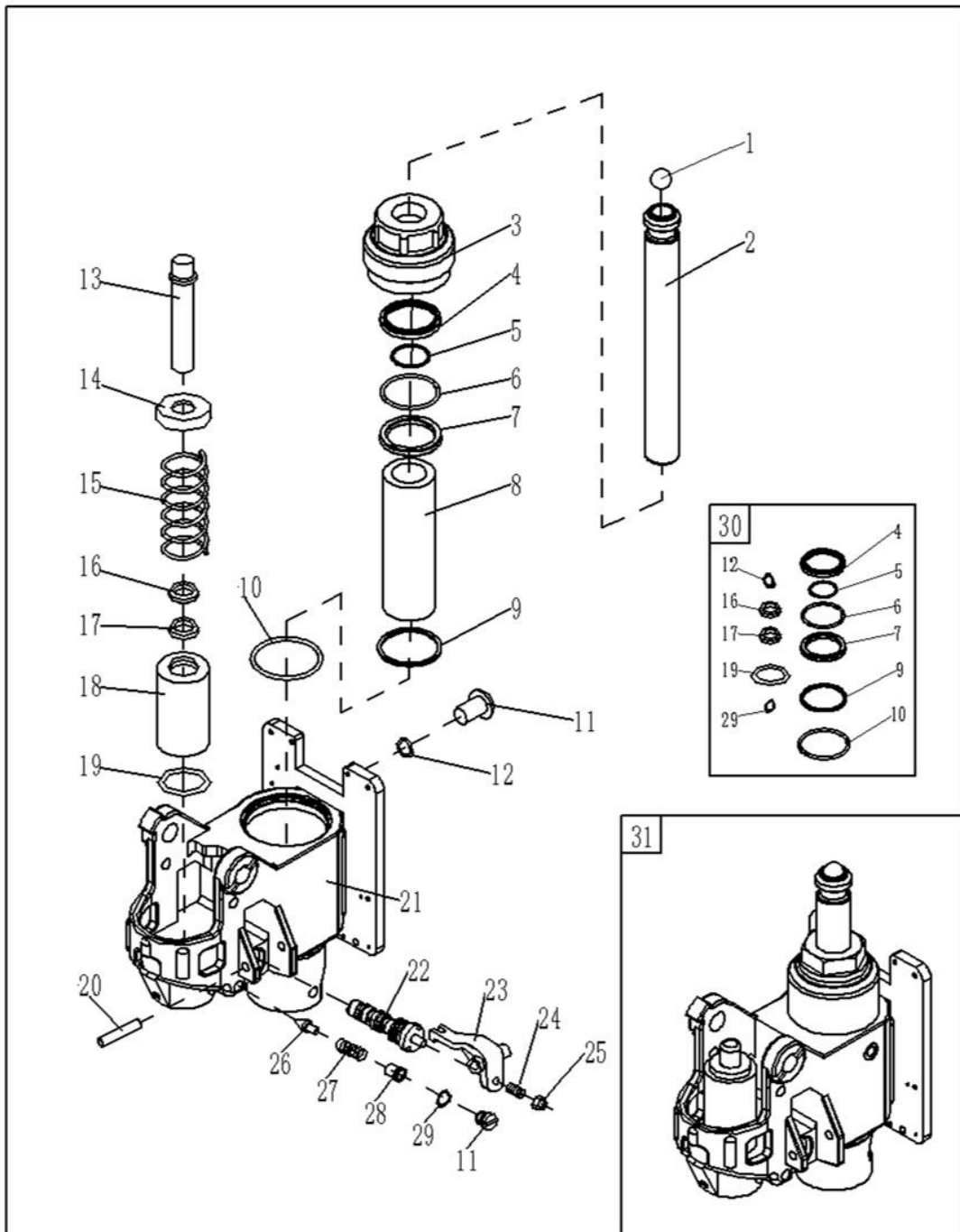

Fig.7 Hydraulic parts (SPTE15X)

No.	Art No.	Description	Qty.	Note
1	910701100019	Steel ball	1	18
2	502124020001	Piston rod	1	

3	502624020010	Cylinder cover	1	
4	910800400011	Rubber dust ring	1	30x38x6.5
5	910800100037	O ring	1	30x3.55
6	910800100036	O ring	1	45x3.55
7	910800300014	Sealing ring	1	30x40x6
8	502624020012	Inner cylinder barrel	1	
9	910800100030	O ring	1	40x3.55
10	910800100032	O ring	1	75x3.1
11	502624020011	Vent plug	2	
12	950100200002	Sealing washer	1	15x10x3
13	300523520005	Piston rod	1	Φ 18x86.5
14	302523520005	Spring cover	1	
15	502624020004	Spring	1	Φ 45xΦ 6x99
16	910800400012	Rubber dust ring	1	18x26x5
17	910800300012	Sealing ring	1	18x26x5
18	300523520004	Cylinder	1	Φ 35.5xΦ 18x60
19	300523520002	Sealing washer	1	Φ 18x2
20	910600400048	Dowel pin	1	8x50
21	502124010000	Pump body	1	
22	300523510003	Hydraulic valve assembly	1	
23	300523520001	Bar	1	
24	910200800021	Screw	1	M8x20
25	910300100006	Nut	1	M8
26	301023520016	Safety valve core	1	
27	300523520027	Spring	1	Φ 6.3xΦ 2x19.5
28	300523520026	Screw	1	
29	910800900006	Sealing washer	1	10
30	502198510006	Seal kit	1	
31	502124001000	Hydraulic assembly	1	

Fig. 8 Hydraulic parts (PTE15X)

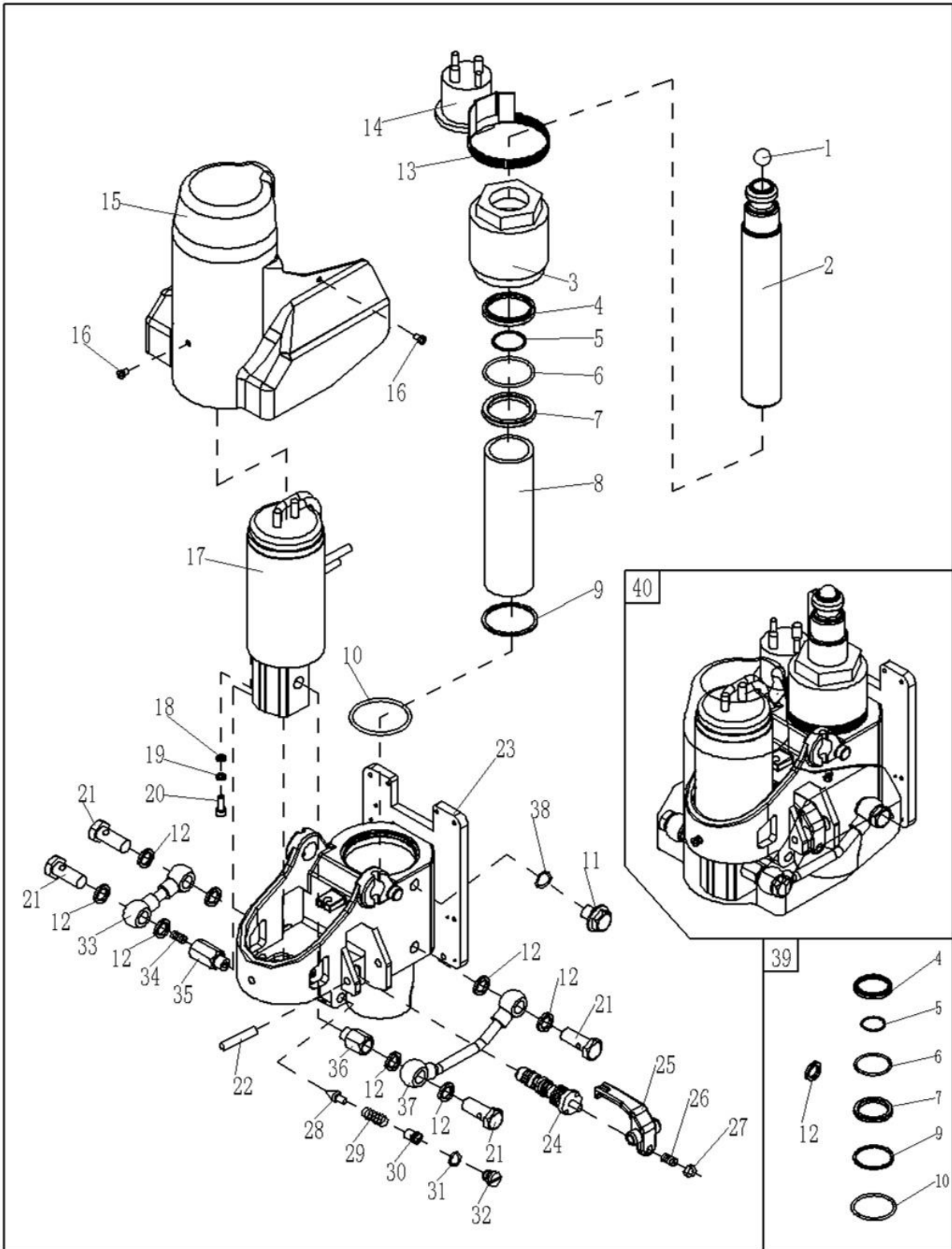

Fig.8 Hydraulic parts (PTE15X)

No.	Art No.	Description	Qty.	Note
1	910701100019	Steel ball	1	18
2	502024020002	Piston rod	1	
3	503224020003	Cylinder cover	1	
4	910800400009	Rubber dust ring	1	40x48x6.5
5	910800100030	O ring	1	40x3.55
6	910800100029	O ring	1	54.5x3.55
7	910800300002	Sealing ring	1	40x50x6
8	503224020004	Inner cylinder barrel	1	
9	910800100031	O ring	1	43.7x3.55
10	910800100032	O ring	1	75x3.1
11	951100200002	Vent plug	1	G1/4
12	910800900003	Sealing washer	9	14
13	502198510010	Hoop	1	KG01
14	920700100007	Pump station	1	
15	503224020006	Motor protective cover	1	
16	910200500037	Screw	3	M5x10
17	950900100021	Hydraulic pump	1	
18	910400100005	Washer	2	6
19	910400500005	Washer	2	6
20	910200200035	Screw	2	M6x16
21	503224020005	Bolt	4	G1/4x33
22	910600400048	Dowel pin	1	8x50
23	502124010001	Pump body	1	
24	502024010005	Hydraulic valve assembly	1	
25	502024020003	Bar	1	
26	910200800021	Screw	1	M8x20
27	910300100006	Nut	1	M8
28	301023520016	Safety valve core	1	
29	300523520027	Spring	1	Φ 6.3xΦ 2x19.5
30	300523520026	Screw	1	
31	910800900006	Seal washer	1	10
32	502624020011	Screw plug	1	M10x1

33	503224010003	Steel tube	1	
34	503224010004	Check valve	1	
35	503224020007	Joint	1	
36	503224020008	Joint(short)	1	
37	503224010002	Hydraulic tube	1	
38	951100200002	Vent plug	1	G1/4
39	502198510007	Seal kit	1	
40	502124001001	Hydraulic assembly	1	

Fig. 9 Castors

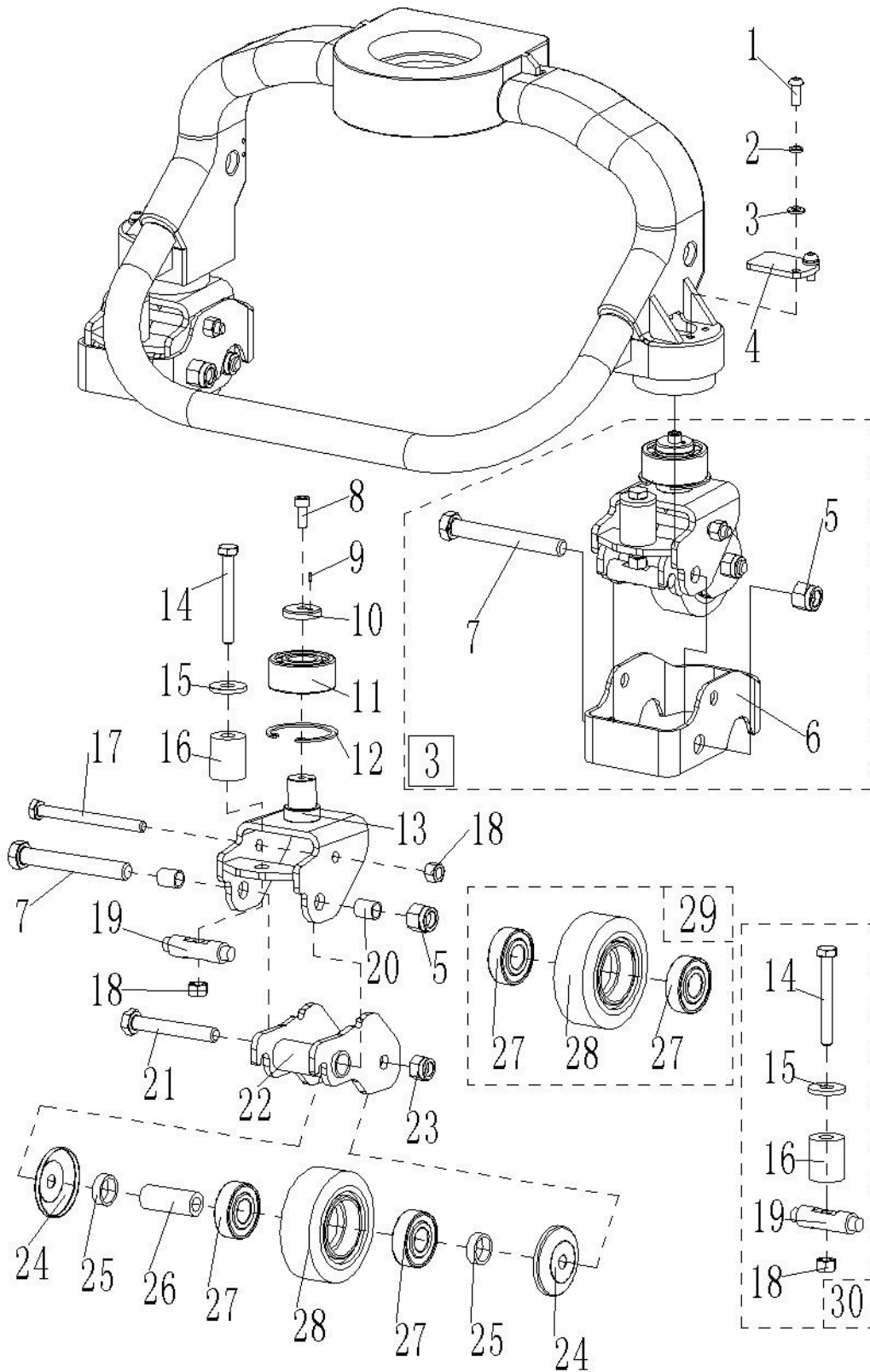

Fig.9 Castors

No.	Art No.	Description	Qty.	Note
1	910200300012	Screw	2	M5x12
2	910400500004	Washer	2	5
3	910400100004	Washer	2	5
4	502013520008	Dust board	1	
5	910300500006	Nut	1	M12
6	502016510002	Apron	1	
7	910100100056	Bolt	1	M12x90
8	910200200034	Screw	1	M6x14
9	910600100001	Pin	1	3x14
10	502016520003	Circlip	1	Φ 27xΦ 7x5
11	910700500001	Bearing	1	3204 A-2Z
12	910401400013	Circlip	1	47
13	502016510001	Wheel frame	1	
14	910100300032	Bolt	1	M8x70
15	910400200003	Washer	1	8
16	502316520012	Spring	1	
17	910100100030	Bolt	1	M8x90
18	910300500004	Nut	2	M8
19	502316520013	Spindle	1	Φ 15x56
20	940500100002	Bushing	2	Φ 12xΦ 15x15
21	910100100037	Bolt	1	M10x70
22	502316510005	Rotating arm	1	
23	910300500005	Nut	1	M10
24	502316520016	Dust cover	2	Φ 50xΦ 30x8
25	502316520015	Spacer	2	Φ 22xΦ 17.5x6.5
26	502316520014	Sleeve	1	Φ 17xΦ 10x43
27	910700200018	Bearing	2	6203
28	940300300017	Castor	1	Φ 80x30
29	502198510008	Castor assembly	1	
30	502198510009	Spring assembly	1	
□,3	502016501000	Castor assembly	1	

Fig.10 Handle bar (SPTE15X)

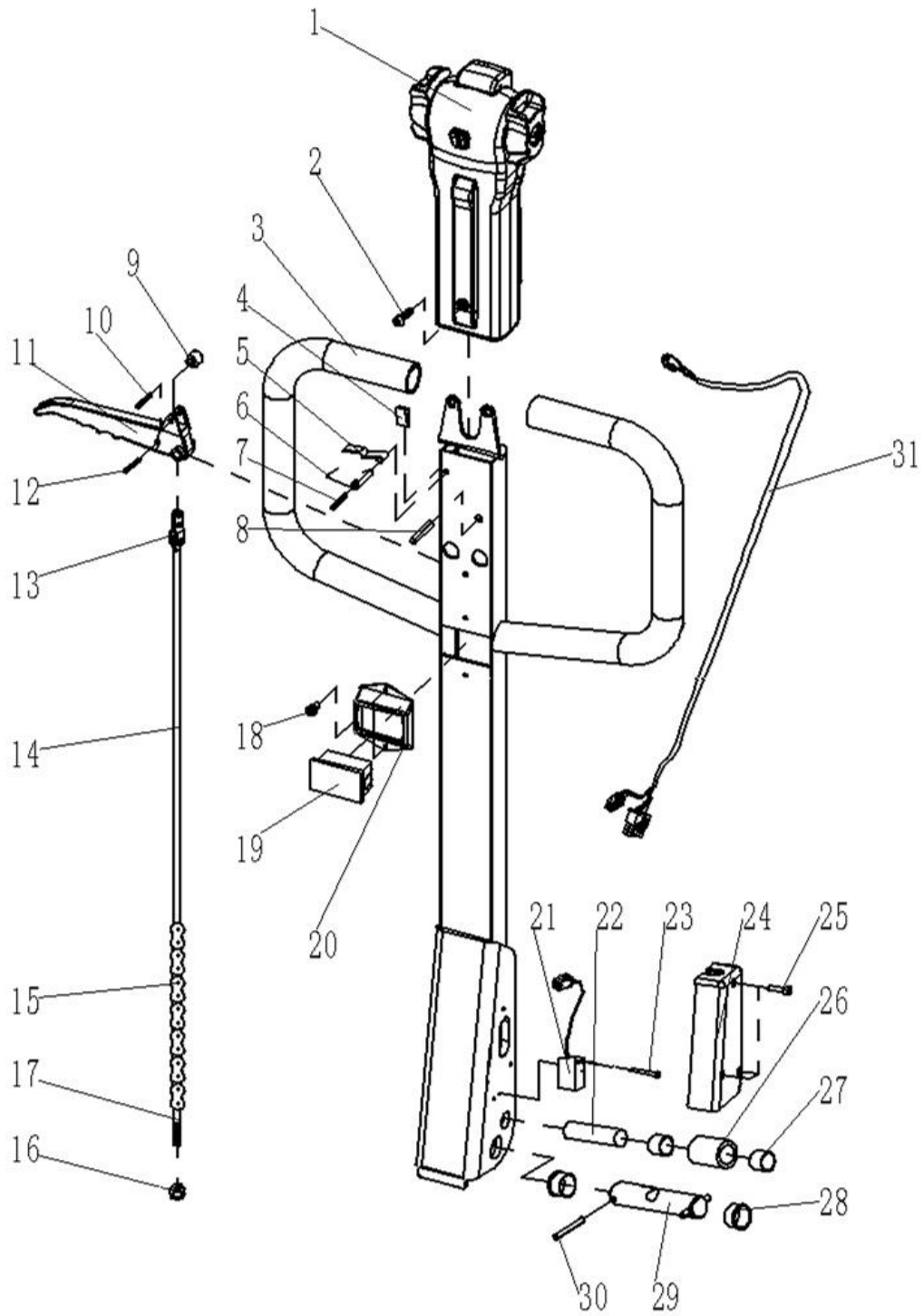

Fig.10 Handle bar (SPTE15X)

No.	Art No.	Description	Qty.	Note
1	922100100005	Handle head	1	
2	910200500036	Screw	3	M5x8
3	502111010000	Handle body	1	
4	301011020007	Rubber pad	1	
5	302511020000	Folder	1	
6	301011020005	Spring	1	
7	910600400015	Dowel pin	1	4x30
8	910600400038	Dowel pin	1	6x30
9	301011020004	Roller	1	Φ 12xΦ 4.5x10
10	910600400011	Dowel pin	1	4x20
11	301011020002	Tiller lever	1	
12	910600400009	Dowel pin	1	4x14
13	301011020001	Connecting plate	1	
14	502111020004	Bar	1	
15	301011020009	Roller chain	1	
16	910300500002	Nut	2	M5
17	301011020006	Connecting bar	1	
18	910200500009	Screw	2	M3x6
19	921100100020	Voltmeter	1	
20	502111020008	Voltmeter cover	1	
21	920200400010	Proximity switch	1	
22	300511020000	Axle	1	
23	910200500016	Screw	2	M3x25
24	503211020008	Protective cover	1	
25	910200500024	Screw	3	M4x16
26	300511020001	Roller	1	
27	940500100003	Bushing	2	Φ 15xΦ 17x15
28	940500200006	Bushing	2	Φ 20xΦ 22x15
29	302311020000	Axle	1	
30	910600400027	Dowel pin	2	5x35

Fig.11 Handle bar (PTE15X)

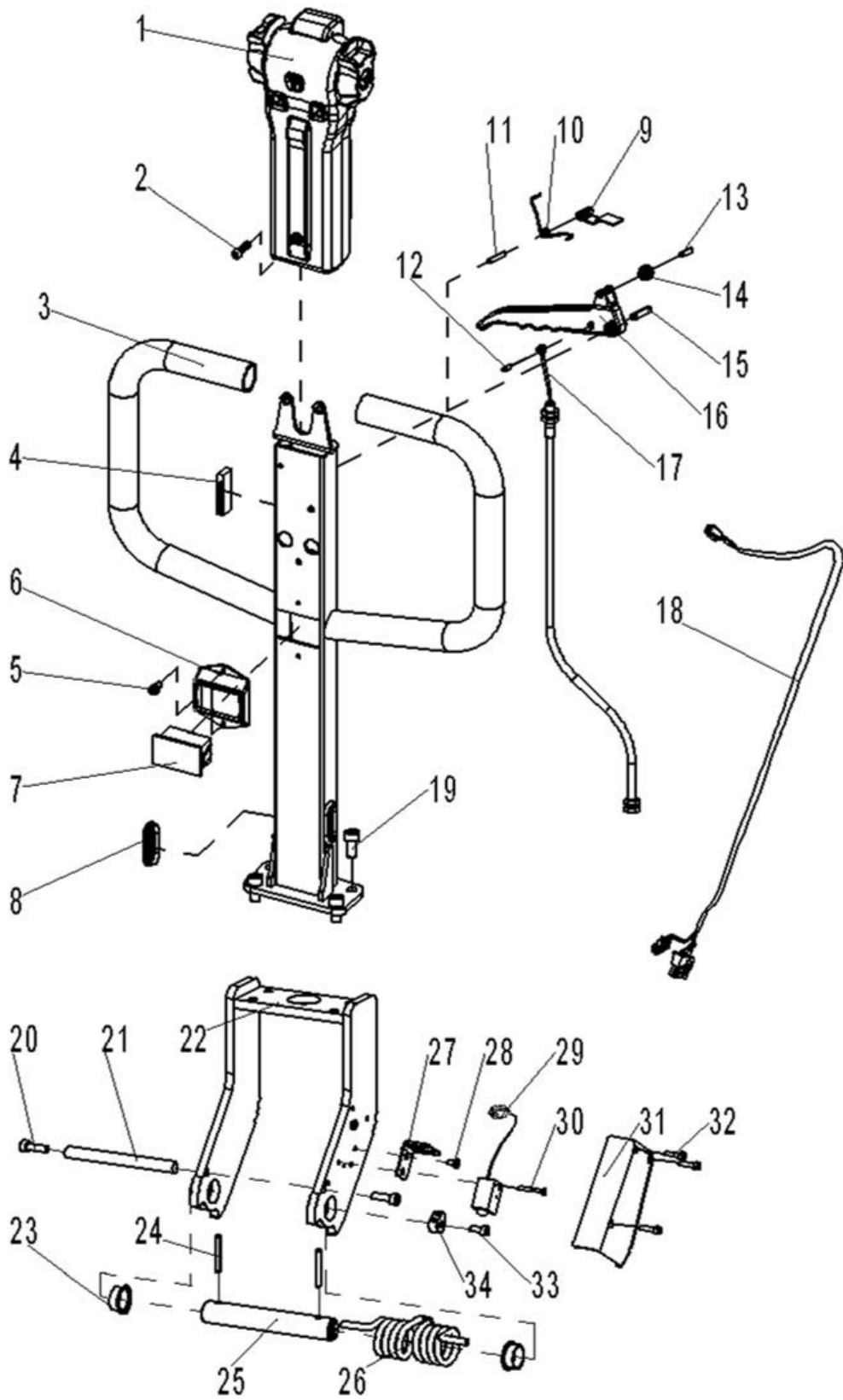

Fig.11 Handle bar (PTE15X)

No.	Art No.	Description	Qty.	Note
1	922100100006	Handle head	1	
2	910200500036	Screw	3	M5x8
3	502111010001	Handle body	1	
4	301011020007	Rubber pad	1	
5	910200500009	Screw	2	M3x6
6	502111020008	Voltameter cover	1	
7	921100100020	Voltameter	1	
8	300511020017	Sheath (circular)	1	
9	302511020000	Folder	1	
10	301011020005	Torsional spring	1	$\Phi 6.6 \times \Phi 1.6 \times 3.6$
11	910600400015	Dowel pin	1	4x30
12	910600400009	Dowel pin	1	4x14
13	910600400011	Dowel pin	1	4x20
14	301011020004	Roller	1	
15	910600400038	Dowel pin	1	6x30
16	301011020002	Tiller lever	1	
17	502111020007	Control steel wire	1	
18	502133010002	Handle electrical cable	1	
19	910200200055	Screw	4	M8x16
20	910200200036	Screw	2	M6x20
21	503211020012	Axle	1	
22	503211010001	Handle flange	1	
23	940500200004	Bushing	2	$\Phi 20 \times \Phi 22 \times 10$
24	910600400027	Dowel pin	2	5x35
25	503211020007	Axle	1	
26	503211020010	Torsional spring	1	
27	503211020009	Plug fixing plate	1	
28	910200500034	Screw	2	M4x8
29	920200400010	Proximity switch	1	
30	910200500016	Screw	2	M3x25

31	503211020008	Plastic cover	1	
32	910200500024	Screw	3	M4x16
33	910200200022	Screw	1	M5x12
34	503211020011	Proximity switch indication block	1	

Fig. 12 Truck parts

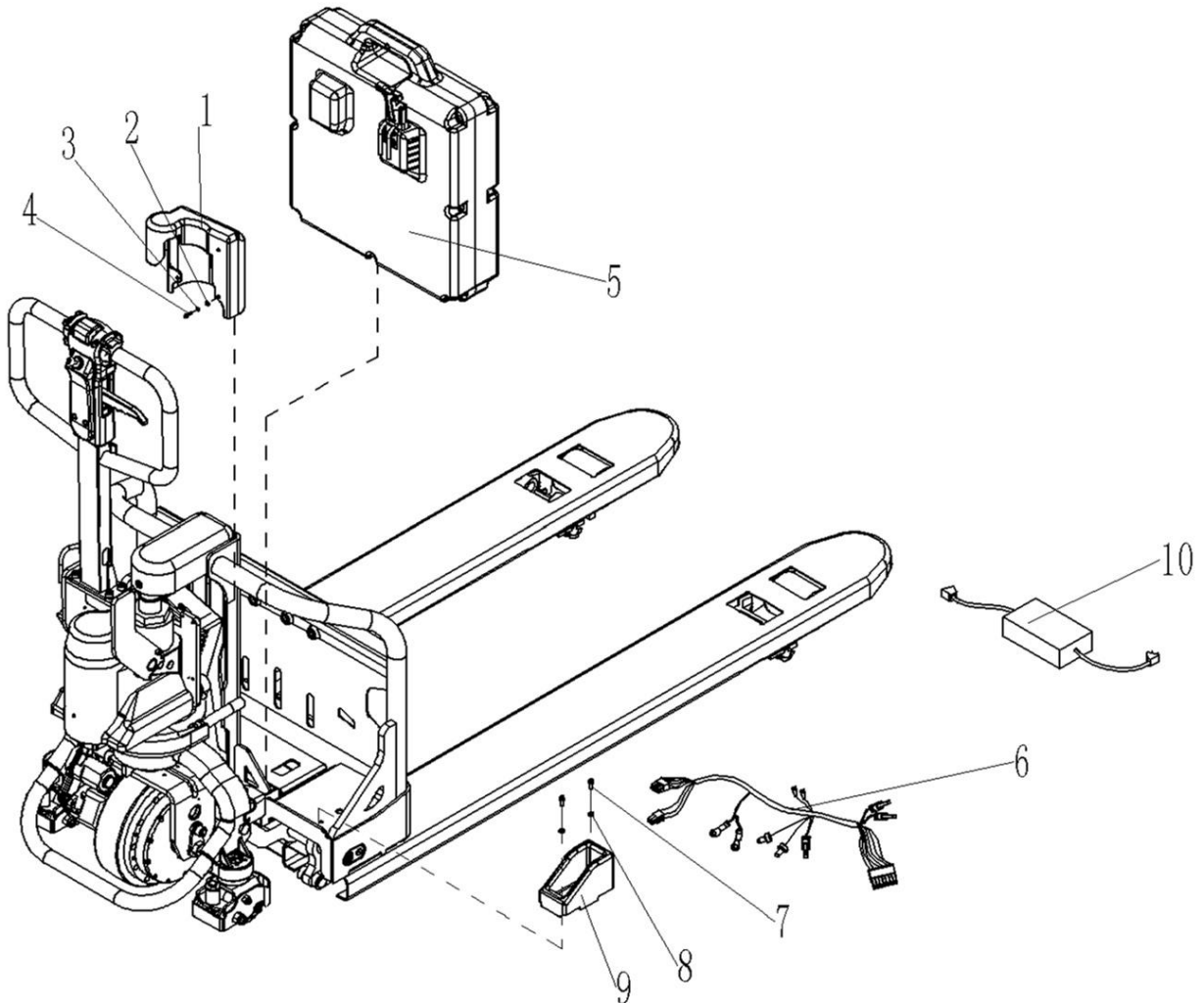

Fig. 12 Truck parts

No.	Art No.	Description	Qty.	Note
1	502024020000	Plastic cover	1	
2	910400100004	Washer	3	5
3	910400500004	Washer	3	5
4	910200200022	Screw	3	M5x12
5	502137001000	Power supply assembly	1	
6	502133010000	Electrical control cable	1	(PTE with EPB)
	502133010004	Electrical control cable	1	(PTE without EPB)
	502133010001	Electrical control cable	1	(SPTe with EPB)
	502133010005	Electrical control cable	1	(SPTe without EPB)
7	910200200035	Screw	4	M6x16 / For 685
8	910400500005	Washer	4	6 / For 685
9	502038520024	Container	2	For 685
10	502136510000	Charger	1	24V3A /Asia
	502136510001	Charger	1	24V3A /England
	502136510002	Charger	1	24V3A /America
	502136510003	Charger	1	24V3A /Europe
	502136510004	Charger	1	24V3A /Australia
	502136510005	Charger	1	24V3A /Italy
	502136510006	Charger	1	24V3A /Sweden

Fig.13 Power supply assembly

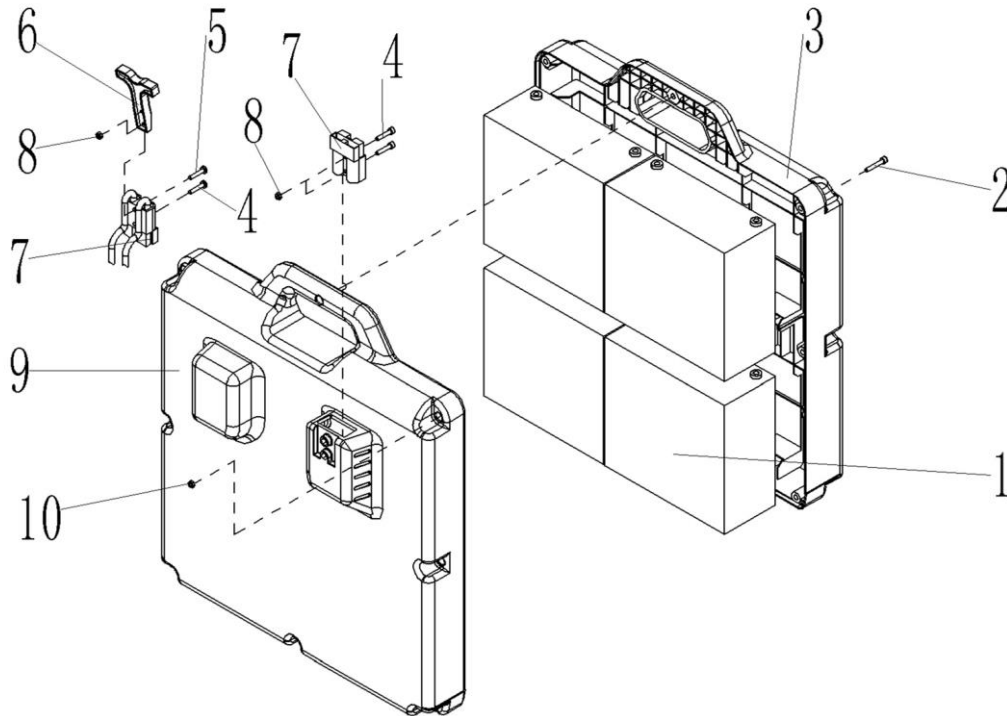

Fig.13 Power supply assembly

No.	Art No.	Description	Qty.	Note
1	920600100024	Battery	4	12V20Ah
2	910200200023	Screw	8	M5x16
3	502137020001	Battery cover (front)	1	
4	910200500027	Screw	3	M4x25
5	910200500028	Screw	1	M4x30
6	920400100010	Plug	1	
7	920400100003	Plug	1	
8	910300100003	Nut	2	M4
9	502137020000	Battery cover (rear)	1	
10	910300100004	Nut	8	M5

Fig.14 Electronic control assembly

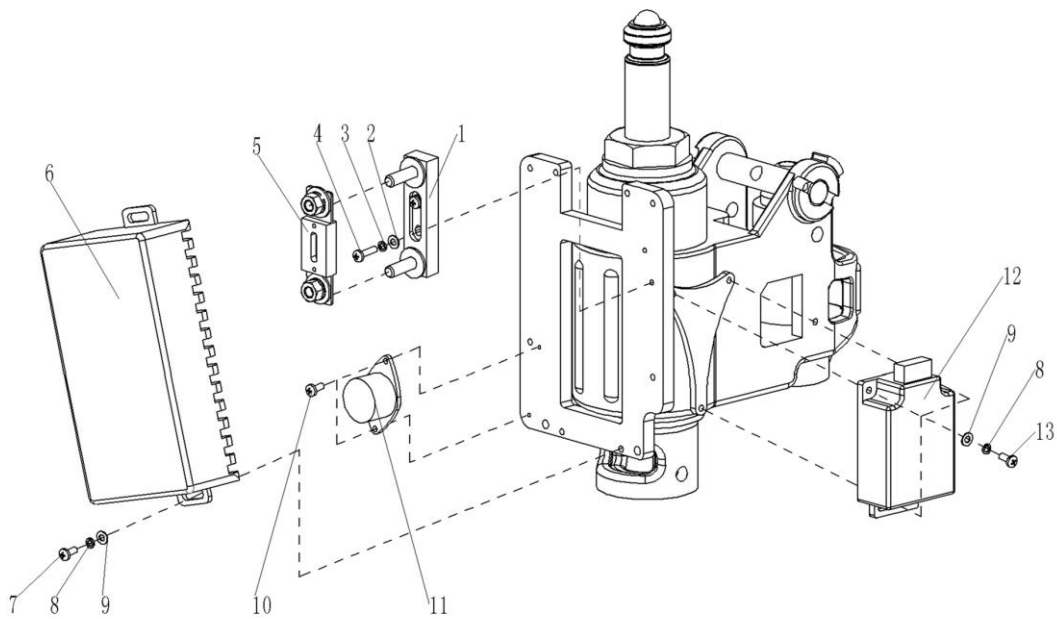

Fig.14 Electronic control assembly

No.	Art No.	Description	Qty.	Note
1	920100400002	Fuse base	1	
2	910400100003	Washer	2	4
3	910400500003	Washer	2	4
4	910200500024	Screw	2	M4x16
5	920100100003	Fuse	1	
6	921400100051	Controller	1	
7	910200200022	Screw	2	M5x12
8	910400500004	Washer	5	5
9	910400100004	Washer	5	5
10	910200500010	Screw	2	M3x8
11	920500100004	Buzzer	1	
12	921200100008	EPB module	1	
13	910200500037	Screw	3	M5x10

Fig. 15 Charger assembly (standard)

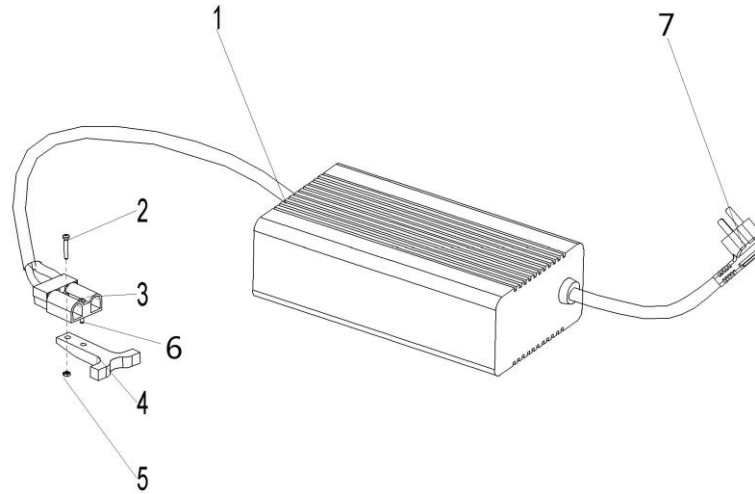

Fig. 15 Charger assembly (standard)

No.	Art No.	Description	Qty.	Note
1	921000200127	Charger	1	
2	910200500027	Screw	1	M4x25
3	920400100003	Plug	1	
4	920400100010	Handle	1	
5	910300500001	Lock nut	2	M4
6	910200500028	Screw	1	M4x30
7	921500200021	Plug	1	Asia
	921500200027	Plug	1	England
	921500200023	Plug	1	America
	921500200022	Plug	1	Europe
	921500200024	Plug	1	Australia
	921500200025	Plug	1	Italy
	921500200026	Plug	1	Sweden

Fig.16 Main cables (SPTE15X)

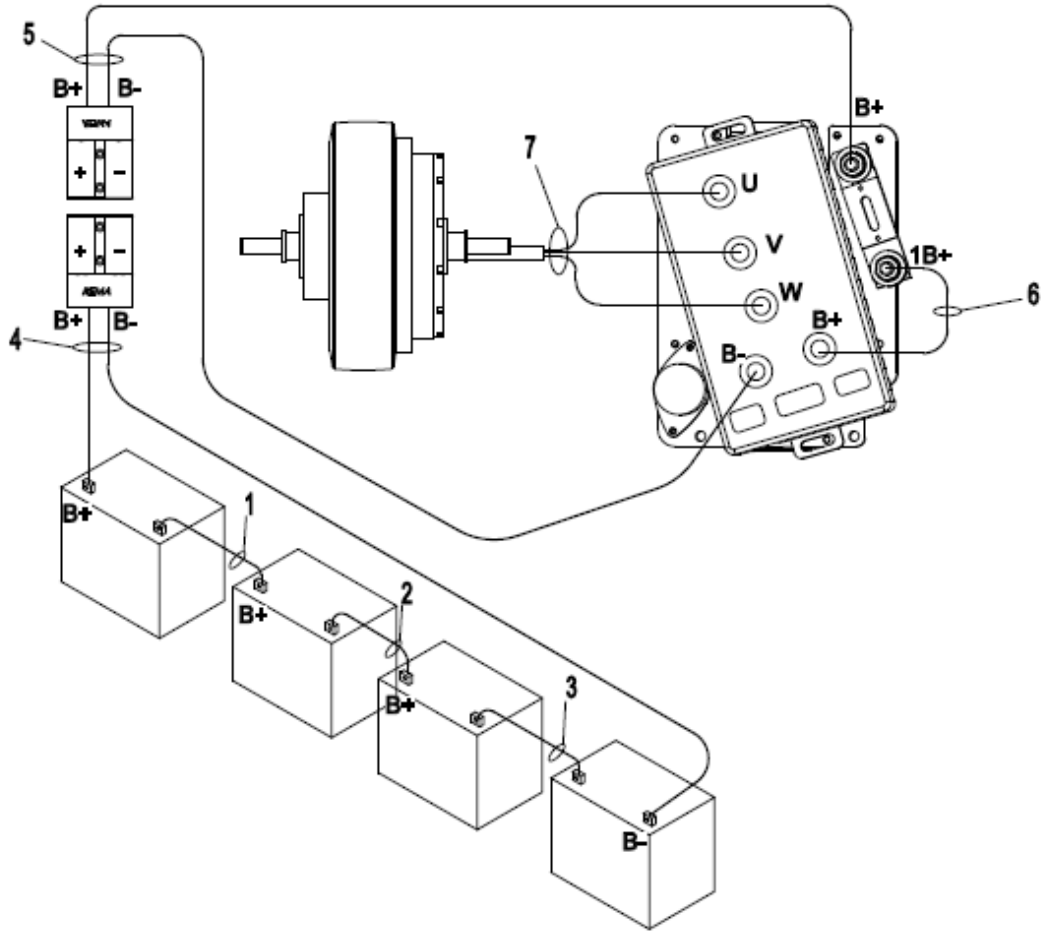

Fig.16 Main cables (SPTE15X)

No.	Art No.	Description	Qty.	Note
1	502133010008	Cable	1	
2	502133010007	Cable	1	
3	502133010009	Cable	1	
4	502133010010	Battery cable	1	
5	502133010012	Main battery cable	1	
6	502133010011	Cable	1	
7	502113510005	Drive motor	1	

Fig.17 Main cables (PTE15X)

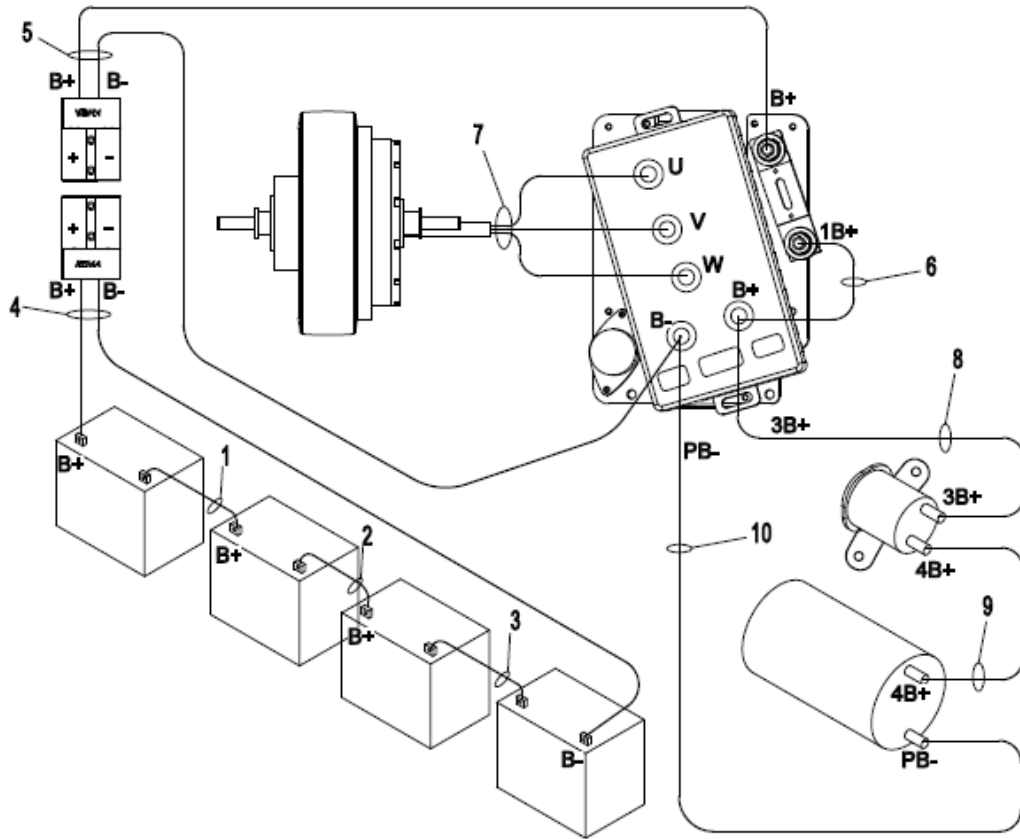

Fig.17 Main cables (PTE15X)

No.	Art No.	Description	Qty.	Note
1	502133010008	Cable	1	
2	502133010007	Cable	1	
3	502133010009	Cable	1	
4	502133010010	Battery cable	1	
5	502133010012	Main battery cable	1	
6	502133010011	Cable	1	
7	502113510005	Drive motor	1	
8	502133010014	Cable	1	
9	502133010015	Cable	1	
10	502133010016	Cable	1	

Fig.18 Sticker for EU

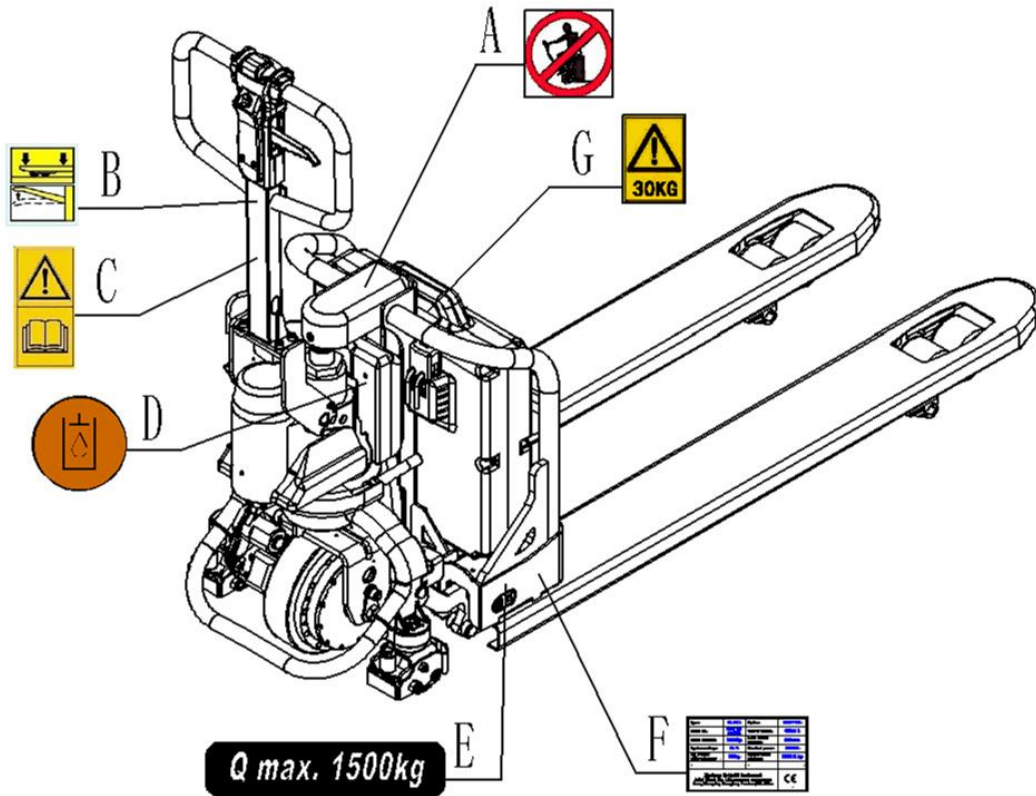

Fig.18 Sticker for EU

No.	Art No.	Description	Qty.	Note
A	941200100003	'No passengers' sticker	1	
B	941200400001	Tiller operation sticker	1	
C	941200300002	Sign read and follow this instruction sticker	1	
D	941200300003	Cylinder sticker	1	
E	941200200020	Sign capacity sticker (1500kg)	1	
F	502147520000	ID plate	1	For SPTE15X
	502147520001	ID plate	1	For PTE15X
G	941200200045	Weight sticker (Battery)	1	

Fig. 19 Sticker for US

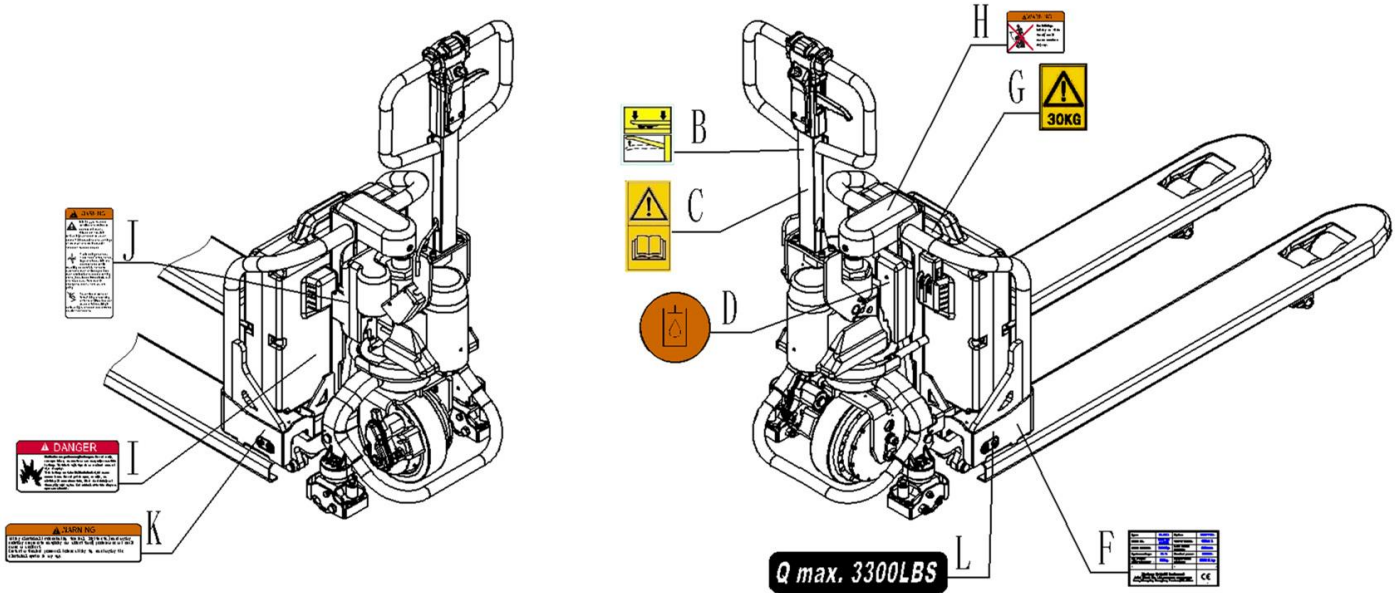

Fig. 19 Sticker for US

No.	Art No.	Description	Qty.	Note
B	941200400001	Tiller operation sticker	1	
C	941200300002	Sign read and follow this instruction sticker	1	
D	941200300003	Cylinder sticker	1	
L	941200200035	Sign capacity sticker (3300LBS)	1	
F	502147520000	ID plate	1	For SPTE15X
	502147520001	ID plate	1	For PTE15X
G	941200200045	Weight sticker (Battery)	1	
H	941200100011	Warning sticker	1	
I	941200100013	Warning sticker	1	
J	941200100009	Warning sticker	1	
K	941200100010	Warning sticker	1	

Easy worn parts list

No.	Part number	Name	Qty.	Fig./Position	Note
1	940500200009	Bushing	4	Fig.1/16	Φ 20xΦ 23x21.5
2	940500100006	Bushing	8	Fig.1/22	Φ 16xΦ 18x15
3	502198510000	Push rod kit	2	Fig.1/23	
4	940500200009	Bushing	4	Fig.2/16	Φ 20xΦ 23x21.5
5	940500100006	Bushing	8	Fig.2/22	Φ 16xΦ 18x15
6	502198510001	Push rod kit	2	Fig.2/23	
7	940500100012	Bushing	4	Fig.3/7	Φ 20xΦ 22x12
8	910700200019	Bearing	8/4(D/S)	Fig.3/11	6204
9	940300300005	Castor	4(D)	Fig.3/12	Φ 80x70
10	940300300023	Castor	2(S)	Fig.3/17	Φ 80x93
11	940500200003	Bushing	4 (D)	Fig.3/18	Φ 18xΦ 20x12
12	502198510002	Wheel set kit	4	Fig.3/19	
13	502198510003	Wheel set kit	2	Fig.3/20	
14	910700600034	Bearing	1	Fig.4/5	32911
15	910700600006	Bearing	1	Fig.4/6	30212
16	940300300004	Wheel	1	Fig.5/1	
17	910800400011	Rubber dust ring	1	Fig.7/4	30x38x6.5
18	910800100037	O ring	1	Fig.7/5	30x3.55
19	910800100036	O ring	1	Fig.7/6	45x3.55
20	910800300014	Sealing ring	1	Fig.7/7	30x40x6
21	910800100030	O ring	1	Fig.7/9	40x3.55
22	910800100032	O ring	1	Fig.7/10	75x3.1
23	910800400012	Rubber dust ring	1	Fig.7/16	18x26x5
24	910800300012	Sealing ring	1	Fig.7/17	18x26x5
25	910800400009	Rubber dust ring	1	Fig.8/4	40x48x6.5

26	910800100030	O ring	1	Fig.8/5	40x3.55
27	910800100029	O ring	1	Fig.8/6	54.5x3.55
28	910800300002	Sealing ring	1	Fig.8/7	40x50x6
29	910800100031	O ring	1	Fig.8/9	43.7x3.55
30	910800100032	O ring	1	Fig.8/10	75x3.1
31	910800900003	Sealing washer	9	Fig.8/12	14
32	910700500001	Bearing	1	Fig.9/11	3204A
33	940500100002	Bushing	2	Fig.9/20	Φ 12x Φ 15x15
34	910700200018	Bearing	2	Fig.9/27	6203
35	940300300017	Castor	1	Fig.9/28	
36	502198510008	Castor assembly	1	Fig.9/29	
37	940500100003	Bushing	2	Fig.10/27	Φ 15x Φ 17x15
38	940500200006	Bushing	2	Fig.10/28	Φ 20x Φ 22x15
39	940500200004	Bushing	2	Fig.11/23	Φ 20x Φ 22x10
40	920100100003	Fuse	1	Fig.14/5	60A